

FIG. RC-2 Reducing Coupling



The RC-2 Reducing Coupling makes it possible to directly connect two different pipe sizes, eliminating the need for two couplings and a reducing fitting. The specially designed reducing coupling gasket with a center rib assures proper positioning of the gasket and prevents the smaller pipe from telescoping into the larger during assembly.

Working pressure ratings shown are for reference only and are based on schedule 40 pipe. For the latest UL/ULC listed, LPCB, VdS and FM Approved pressure ratings versus pipe schedule, see www.anvilintl.com or contact your local Anvil Representative.



Fig. RC-2 Coupling complete with Grade "E" EPDM Gasket.

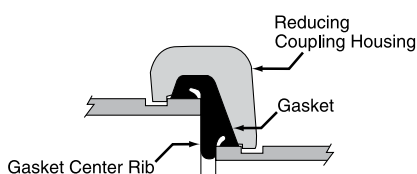

For Listings/Approval Details and Limitations, visit our website at www.anvilintl.com or contact an Anvil® Sales Representative.

LPS 1219: Issue 3.1
Cert/LPCB ref. 519a/24

MATERIAL SPECIFICATIONS

HOUSING:

Ductile Iron conforming to ASTM A-536, Grade 65-45-12

BOLTS:

SAE J429, Grade 5, Zinc Electroplated
ISO 898-1, Class 8.8, Zinc Electroplated followed by a Yellow Chromate Dip

HEAVY HEX NUTS:

ASTM A563, Grade A, Zinc Electroplated
ISO 898-2, Class 8.8, Zinc Electroplated followed by a Yellow Chromate Dip

COATINGS:

- Rust inhibiting paint Color: ORANGE (standard)
 - Hot Dipped Zinc Galvanized (optional)
 - Other available options: Example: RAL3000 or RAL9000 Series
- For other coating requirements contact an Anvil Representative.

LUBRICATION:

- Standard Gruvlok
- Gruvlok Xtreme™ required for freezer applications.

GASKETS: Materials

Properties as designated in accordance with ASTM D-2000.

- Grade "E" EPDM (Green color code)
-40°F to 230°F (Service Temperature Range)(-40°C to 110°C)
Recommended for water service, diluted acids, alkalies solutions, oil-free air and many chemical services.
NOT FOR USE IN PETROLEUM APPLICATIONS.

PROJECT INFORMATION	APPROVAL STAMP
Project:	<input type="checkbox"/> Approved
Address:	<input type="checkbox"/> Approved as noted
Contractor:	<input type="checkbox"/> Not approved
Engineer:	Remarks:
Submittal Date:	
Notes 1:	
Notes 2:	

FIG. RC-2 Reducing Coupling

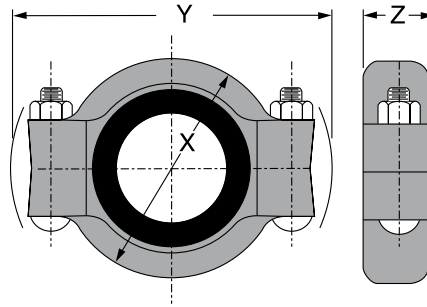

RC-2 REDUCING COUPLING

Nominal Size	Larger O.D.	Smaller O.D.	Max. Working Pressure▲	Max. End Load	Range of Pipe End Separation	Deflection From \perp		Coupling Dimensions			Coupling Bolts		Specified Torque §		Approx. Wt. Ea.
						Per Coupling	Pipe	X	Y	Z	Qty.	Size	Min.	Max.	
In./DN(mm)	In./mm	In./mm	PSI/bar	Lbs./kN	In./mm	Degrees	In./ft. mm/m	In./mm	In./mm	In./mm		In./mm	Ft.-Lbs./N-m	Lbs./Kg	
2 x 1½ 50 x 40	2.375 60.3	1.900 48.3	300 20.7	1,329 5.19	0-½/32 0-0.79	0° 45'	0.16 13.1	3⅞ 92	5⅞ 149	1⅞ 48	2	½ x 2¼ M12 x 76	80 110	110 150	2.0 0.9
2½ x 2 65 x 50	2.875 73.0	2.375 60.3	300 20.7	1,948 8.67	0-½/32 0-0.79	0° 37'	0.13 10.9	4¼ 108	6⅞ 162	1⅞ 48	2	½ x 2¼ M12 x 76	80 110	110 150	3.5 1.6
3 O.D. x 2 76 x 60	2.996 76.1	2.375 60.3	300 20.7	2,115 9.41	0-½ 0-3.2	0° 36'	0.12 9.9	4¼ 108	6⅞ 162	1⅞ 48	2	½ x 2¼ M12 x 76	80 110	110 150	3.3 1.5
3 x 2 80 x 50	3.500 88.9	2.375 60.3	300 20.7	2,886 12.84	0-½/32 0-0.79	0° 31'	0.11 8.9	4⅞ 124	7⅞ 181	1⅞ 48	2	½ x 2¼ M12 x 76	80 110	110 150	4.4 2.0
3 x 2½ 80 x 65	3.500 88.9	2.875 73.0	300 20.7	2,886 12.84	0-½/32 0-0.79	0° 31'	0.11 8.9	4⅞ 124	7⅞ 181	1⅞ 48	2	½ x 2¼ M12 x 76	80 110	110 150	4.1 1.9
3 x 3 O.D. 88 X 76	3.500 88.9	2.996 76.1	300 20.7	2,886 12.84	0-½ 0-3.2	0° 31'	0.11 8.9	4⅞ 124	7⅞ 181	1⅞ 48	2	½ x 2¼ M12 x 76	80 110	110 150	4.0 1.8
4 x 2 100 x 50	4.500 114.3	2.375 60.3	300 20.7	4,771 21.22	0-¾/32 0-2.38	1° 12'	0.25 20.8	6¼ 159	8⅞ 225	2 51	2	¾ x 3½ M16 x 95	100 135	130 175	8.9 4.0
4 x 2½ 100 x 65	4.500 114.3	2.875 73.0	300 20.7	4,771 21.22	0-¾/32 0-2.38	1° 12'	0.25 20.8	6¼ 159	8⅞ 225	2 51	2	¾ x 3½ M16 x 95	100 135	130 175	7.9 3.6
4 x 3 100 x 80	4.500 114.3	3.500 88.9	300 20.7	4,771 21.22	0-¾/32 0-2.38	1° 12'	0.25 20.8	6¼ 159	8⅞ 225	2 51	2	¾ x 3½ M16 x 95	100 135	130 175	6.7 3.0
4 x 3 O.D. 114 X 76	4.500 114.3	2.996 76.1	300 20.7	4,771 21.22	0-¾/32 0-4.8	1° 12'	0.25 20.8	6¼ 159	8⅞ 225	2 51	2	¾ x 3½ M16 x 95	100 135	130 175	7.6 3.5
5½ O.D. x 4 139 X 114	5.500 139.7	4.500 114.3	300 20.7	7,128 31.71	0-¾/16 0-4.8	1° 58'	0.20 10.8	7¼ 184	10⅞ 270	2⅞ 54	2	¾ x 4½ M20 x 115	100 135	130 175	11.4 5.2
5 x 3 125 x 80	5.563 141.3	3.500 88.9	300 20.7	7,292 32.44	0-¼ 0-6.4	1° 58'	0.20 16.8	7¼ 184	10⅞ 270	2⅞ 54	2	¾ x 4½ M20 x 115	130 175	180 245	10.4 4.7
5 x 4 125 x 100	5.563 141.3	4.500 114.3	300 20.7	7,292 32.44	0-¾/32 0-2.38	1° 58'	0.20 16.8	7¼ 184	10⅞ 270	2⅞ 54	2	¾ x 4½ M20 x 115	130 175	180 245	11.4 5.2
6½ O.D. x 3 165 X 88	6.500 165.1	3.500 88.9	300 20.7	9,955 44.28	0-¼ 0-6.4	1° 20'	0.26 18.2	8¼ 210	11⅞ 295	2⅞ 54	2	¾ x 4½ M20 x 115	130 175	180 245	15.0 6.8
6½ O.D. x 4 165 X 114	6.500 165.1	4.500 114.3	300 20.7	9,955 44.28	0-¼ 0-6.4	1° 20'	0.26 18.2	8¼ 210	11⅞ 295	2⅞ 54	2	¾ x 4½ M20 x 115	130 175	180 245	13.6 6.2
6 x 4 150 x 100	6.625 168.3	4.500 114.3	300 20.7	10,341 46.00	0-¾/32 0-2.38	0° 49'	0.17 14.1	8¼ 210	11⅞ 295	2⅞ 54	2	¾ x 4½ M20 x 115	130 175	180 245	13.4 6.1
6 x 5 150 x 125	6.625 168.3	5.562 141.3	300 20.7	10,341 46.00	0-¾/32 0-2.38	0° 49'	0.17 14.1	8½ 216	11⅞ 295	2⅞ 54	2	¾ x 4½ M20 x 115	130 175	180 245	13.5 6.1
8 x 6 200 x 150	8.625 219.1	6.625 168.3	300 20.7	17,528 77.97	0-¾/32 0-2.38	0° 37'	0.13 10.9	10½ 267	14 365	2¼ 57	2	¾ x 4½ M20 x 115	130 175	180 245	17.7 8.0
8 x 6½ O.D. 219 X 165	8.625 219.1	6.500 165.1	300 20.7	17,528 77.97	0-¼ 0-6.4	0° 37'	0.13 10.9	10½ 267	14 365	2¼ 57	2	¾ x 4½ M20 x 115	130 175	180 245	18.3 8.3

Not for use in copper systems.

Range of Pipe End Separation and Angular Deflection values are for roll grooved pipe and may be doubled for cut groove pipe.

See technical data section for coupling data chart notes.

§ - For additional Bolt Torque information see Technical Data Section.

▲ - Working Pressure Ratings are for reference only and based on Sch. 10 and Sch. 40 pipe. For the latest UL/ULC, FM, VdS and LPCB pressure ratings versus pipe schedule, please visit anvilintl.com or contact your local Anvil Representative.

Other sizes available, contact an Anvil Representative.



The instructions are based on pipe grooved in accordance with SPF® grooving specifications. Check pipe ends for proper groove dimensions and to assure that the pipe ends are free of indentations and projections which would prevent proper sealing.

ALWAYS USE A GRUVLOK® SPF/ANVIL® LUBRICANT FOR PROPER COUPLING ASSEMBLY. Thorough lubrication of the external surface of the gasket is essential to prevent pinching and possible damage to the gasket. For temperatures above 150°F (65°C) and below 32°F (0°C) use Gruvlok® SPF/Anvil® Xtreme Lubricant™ and lubricate all gasket surfaces, internal and external. See Gruvlok SPF/Anvil Lubricants in the Technical Data section of the Anvil SPF catalog for additional important information.



1 Check and lubricate gasket
Check gasket to be sure it is compatible for the intended service. Apply a thin coating of Gruvlok SPF/Anvil Xtreme Lubricant to the outside and sealing lips of the gasket. Be careful that foreign particles do not adhere to lubricated surfaces.



2 Gasket installation
Place the smaller opening of the gasket over the smaller pipe. Angle the gasket over the pipe end and pull the gasket lip open around the circumference of the pipe. The center leg of the gasket should make flush contact with the pipe end and will prevent telescoping of the smaller pipe inside the larger.



3 Alignment
Align the adjoining pipe center lines, and insert the larger pipe end into the gasket. Angle the pipe end slightly to the face of the gasket and tilt the pipe into the gasket to ease assembly.



4 Housings
Place the coupling housing halves over the gasket, making sure the housing keys engage the grooves. Insert bolts and turn nuts finger tight.



5 Tighten nuts
Tighten the nuts alternately and equally to the specified bolt torque. The housing bolt pads must make metal-to-metal contact.
Caution: Uneven tightening may cause the gasket to pinch.



6 Assembly complete
Visually inspect the pipe joint to assure the coupling keys are fully engaged in the pipe grooves and the bolt pads are in firm even metal-to-metal contact on both sides of the coupling.

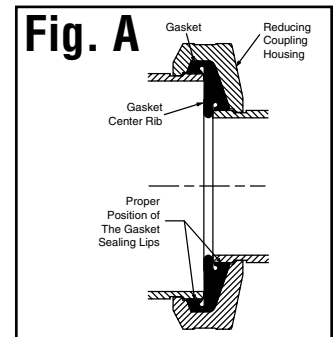

Note: Fig. A illustrates the correct position of the Reducing Coupling gasket and housing properly assembled onto adjacent pipe ends.

Caution: In vertical installations the pipes must be supported to prevent telescoping during installation.

Specified Bolt Torque

Specified bolt torque is for the oval neck track bolts used on SPF® couplings. The nuts must be tightened alternately and evenly until fully tightened.

Caution: Proper torquing of coupling bolts is required to obtain specified performance. **Over torquing the bolts may result in damage to the bolt and/or casting which could result in pipe joint separation.** Under torquing the bolts may result in lower pressure retention capabilities, lower bend load capabilities, joint leakage and pipe joint separation. Pipe joint separation may result in significant property damage and serious injury.

ANSI Specified Bolt Torque			Metric Specified Bolt Torque		
Bolt Size	Wrench Size	Specified Bolt Torque*	Bolt Size	Wrench Size	Specified Bolt Torque*
<i>In.</i>	<i>In.</i>	<i>Ft.-Lbs</i>	<i>mm</i>	<i>mm</i>	<i>N-M</i>
1/2	7/8	80-100	M12	22	110-150
5/8	1 1/16	100-130	M16	24	135-175
3/4	1 1/4	130-180	M20	30	175-245

* Non-lubricated bolt torque

* Non-lubricated bolt torque