

	<h1 style="margin: 0;">TECHNICAL DATA</h1>	<p>2-1/2" & 3" (DN65 & DN80) MODEL F DELUGE VALVE VERTICAL CONVENTIONAL TRIM CHART</p> <p>Maximum 250 PSI Water Working Pressure</p>
---	--	---

The Viking Corporation, 210 N Industrial Park Drive, Hastings MI 49058
 Telephone: 269-945-9501 Technical Services: 877-384-5464 Fax: 269-818-1680 Email: techsvcs@vikingcorp.com

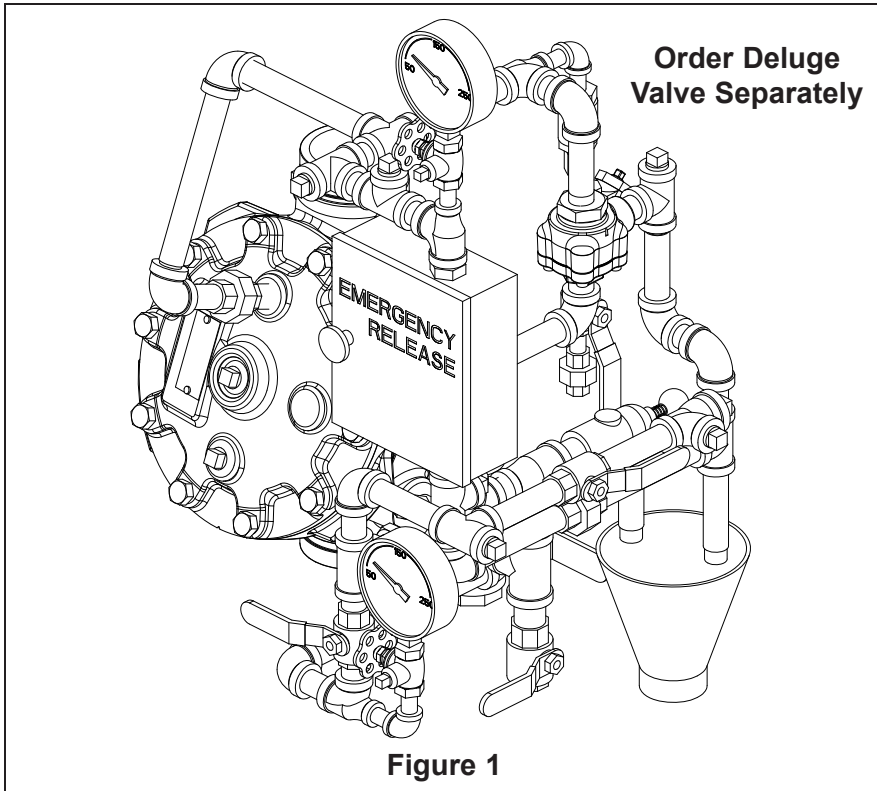

This Trim Chart is for use with the following Viking Trim Sets		
Valve Size	Galvanized Trim Part No.	Brass Trim Part No.
2-1/2" (DN65) & 3" (DN80)	14636-1	14636-2
This Trim is for use with the following Release Module Trim Kits		
Release Type	Galvanized*	Brass**
Pneumatic	10809	10811
Electric	10830	10832
Electric/ Pneumatic	12661-1	12661-2
Pneumatic/ Pneumatic	12662-1	12662-2
<p>* Standard Trim sets for Model F Deluge Valves consist of galvanized nipples and fittings. **Refer to Technical Data describing the Halar® Coated Deluge Valve and the <i>Viking Foam Systems Engineering and Design Data</i> book for applications where brass trim is recommended. Note: Nipple lengths for brass trim may vary from those shown on this Trim Chart.</p>		

Notes: For use with Trim Chart on Page 239a

Note: When viewing this data page online, [blue text](#) represents hyperlinks and will open the appropriate data page when clicked.

General Notes:

- Valve must be trimmed as shown. Any deviation from trim size or arrangement may affect the proper operation of the valve.
- All pipe and fittings shall be galvanized or brass except when other materials are specified in the Technical Data for the Halar® Coated Deluge Valve.
- Gauges are brass as furnished with trim.
- When Model F Deluge Valves are used on pre-mixed Foam Systems, trim piping must be of copper pipe with brass fittings unless otherwise specified in the Technical Data for the Halar® Coated Deluge Valve or the *Viking Foam Systems Engineering and Design Data* book.
- Dimensions in parentheses are millimeter and may be approximations.

- Note 1:** 1/2" (15 mm) NPT plugged outlet provided for connecting certain optional components and associated trim.
- Note 2:** Release System connection. Viking Deluge and Flow Control Valves are compatible with hydraulic, pneumatic, and electric release systems. A Pneumatic Actuator is required on all Viking Deluge Valves and Flow Control Valves equipped with Pneumatic Release Systems.
- Note 3:** Alarm Connections: Connect alarm line piping to 3/4" (20 mm) NPT outlet. When using a Water Motor Alarm, a strainer is required. 1/2" (15 mm) NPT outlet is for electric Alarm Pressure Switch.
- Note 4:** Optional non-interruptible connection for Alarm Pressure Switch to activate electric alarm panel. Note: After the Deluge Valve trips, this location cannot be shut off. Alarms may operate until the outlet chamber of the deluge valve is de-pressurized below the set point of the Alarm Pressure Switch.
- Note 5:** Viking Drain Check Valve is manufactured with a 0.067" (1.7 mm) orifice to allow alarm line to drain. DO NOT substitute. Check label for proper orientation.
- Note 6:** Inlet side of PORV is connected to the top chamber of the deluge valve. Inlet of PORV should be facing up. Outlet goes to open drain.



TECHNICAL DATA

2-1/2" & 3" (DN65 & DN80) MODEL F DELUGE VALVE VERTICAL CONVENTIONAL TRIM CHART

Maximum 250 PSI Water Working Pressure

The Viking Corporation, 210 N Industrial Park Drive, Hastings MI 49058

Telephone: 269-945-9501 Technical Services: 877-384-5464 Fax: 269-818-1680 Email: techsvcs@vikingcorp.com

Refer to page 239a for General Notes and Notes 1 through 6.

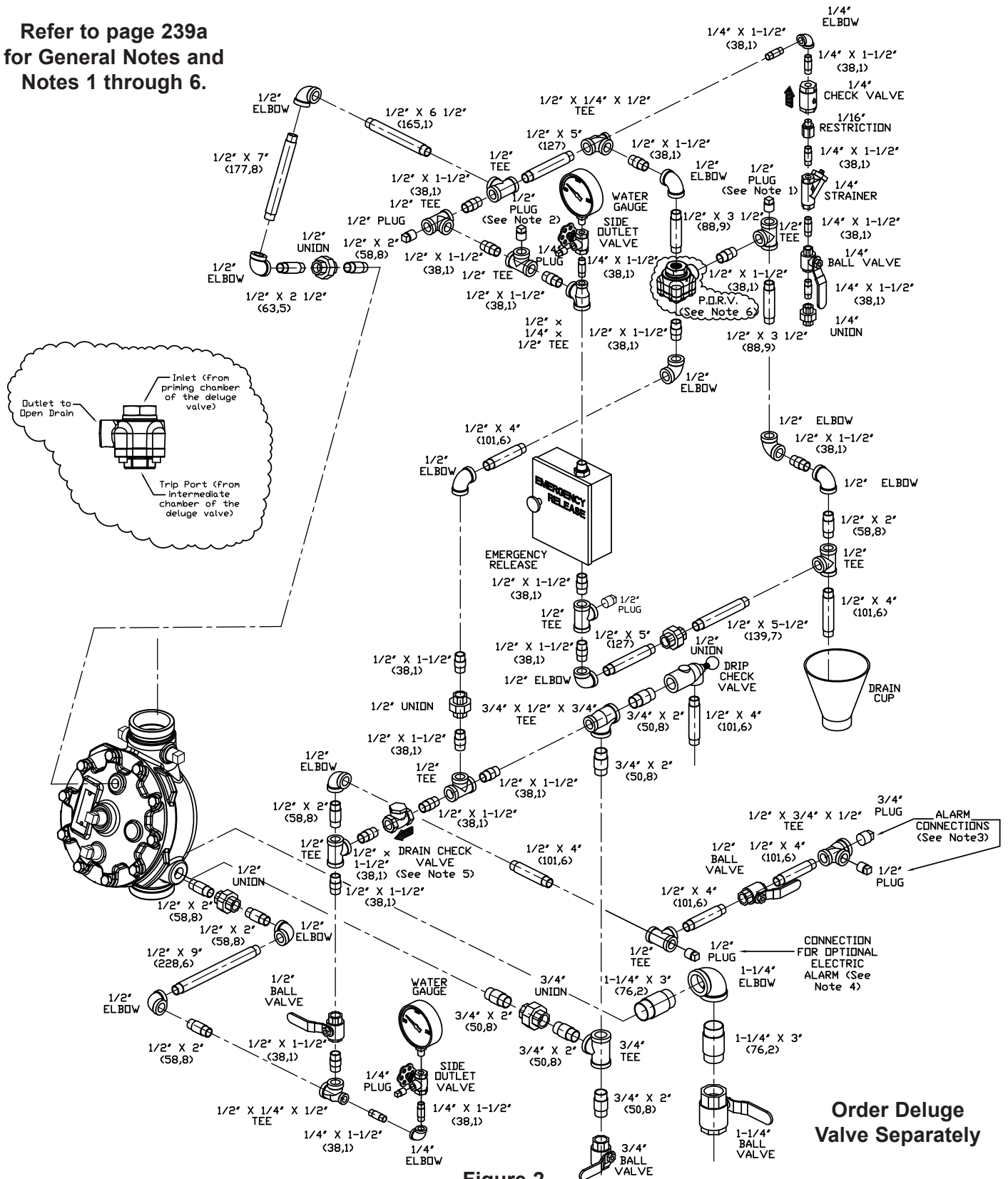

Figure 2

Order Deluge Valve Separately



TECHNICAL DATA

**2-1/2" & 3" (DN65 & DN80) MODEL
F DELUGE VALVE VERTICAL
CONVENTIONAL TRIM CHART**
Maximum 250 PSI Water Working Pressure

The Viking Corporation, 210 N Industrial Park Drive, Hastings MI 49058

Telephone: 269-945-9501 Technical Services: 877-384-5464 Fax: 269-818-1680 Email: techsvcs@vikingcorp.com

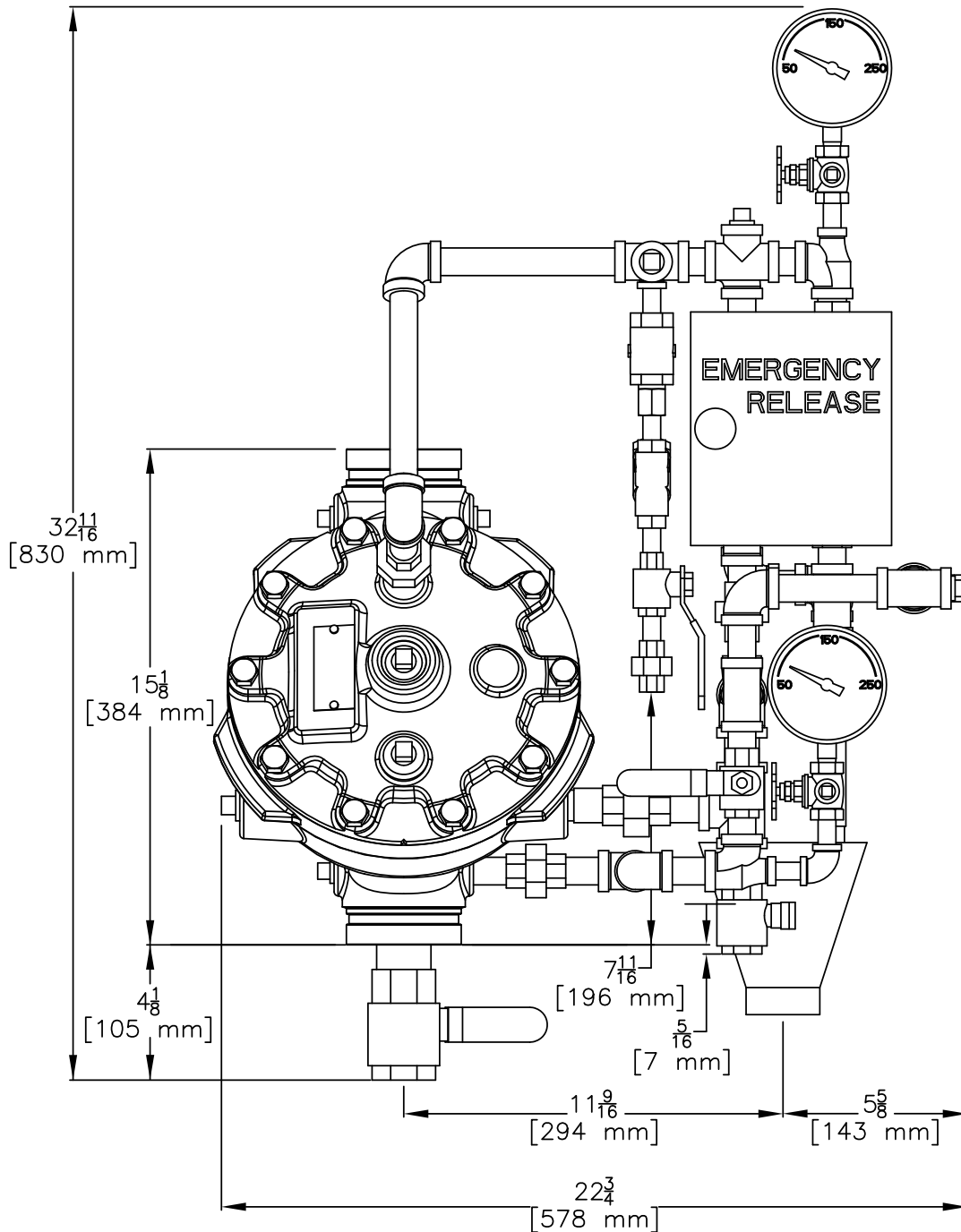

Figure 3a: Installation Dimensions



TECHNICAL DATA

2-1/2" & 3" (DN65 & DN80) MODEL F DELUGE VALVE VERTICAL CONVENTIONAL TRIM CHART

Maximum 250 PSI Water Working Pressure

The Viking Corporation, 210 N Industrial Park Drive, Hastings MI 49058

Telephone: 269-945-9501 Technical Services: 877-384-5464 Fax: 269-818-1680 Email: techsvcs@vikingcorp.com

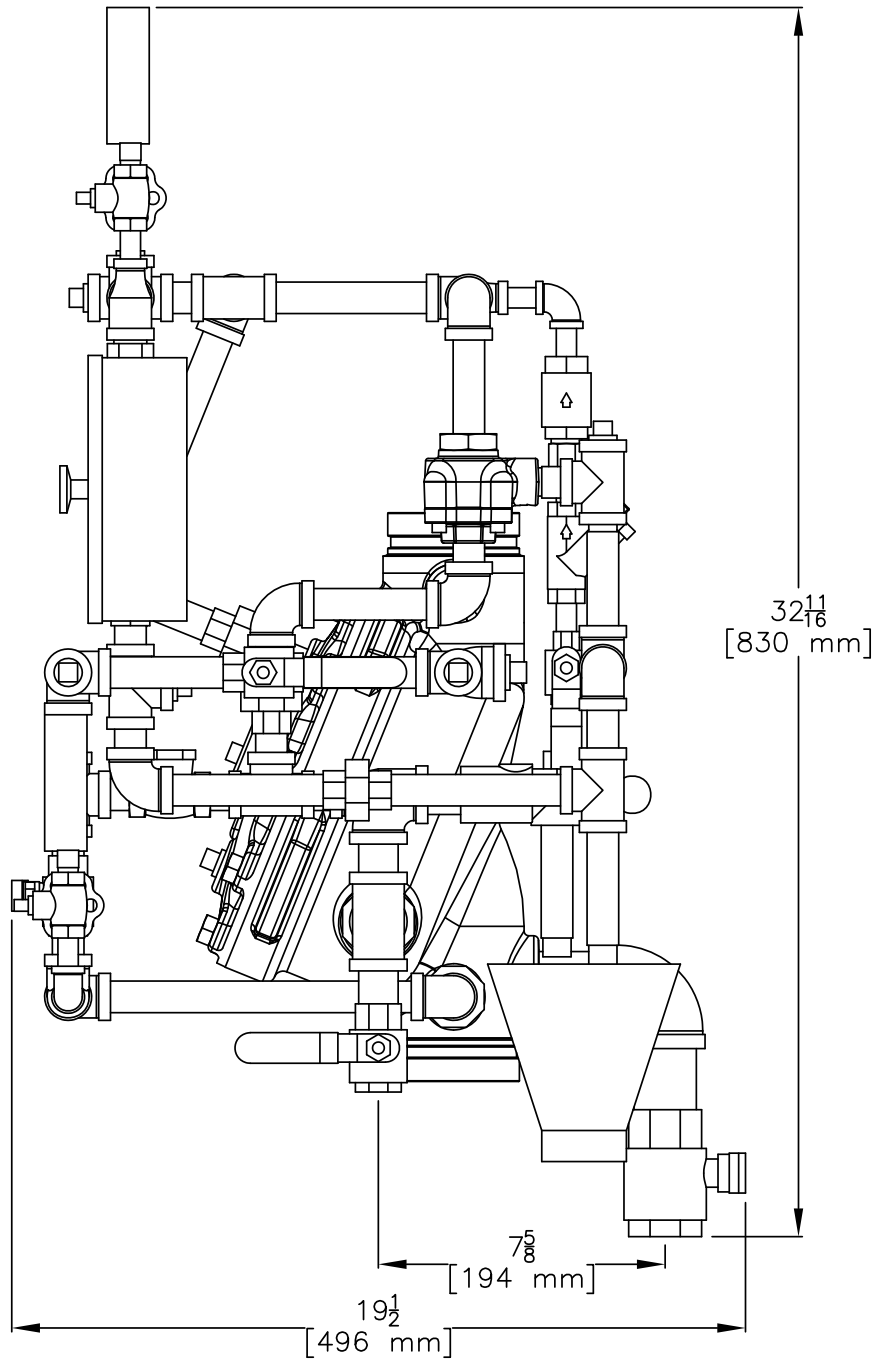

Figure 3b: Installation Dimensions